



FLAT FEEDER



PNEUMATIC CONTROL PANEL



CONTROL PANEL



**BOIX**

MACHIN  
AND GLU  
TRA



	By injection, hot melt. Nordson (cap. 9 kg.)
	1.500 to 2.000 pieces / hour (adjustable)
	4.5Kw. machine
ARD	380 v. (3P + N + E) - 50 Hz
	900
	By vacuum
	15 min.
	150
	6 bar

∇:

for auto-lock boxes without glue equipment.

either white or green.

activating the hot melt equipment.

working in line ; where the machine makes the boxes that the line

(mm):

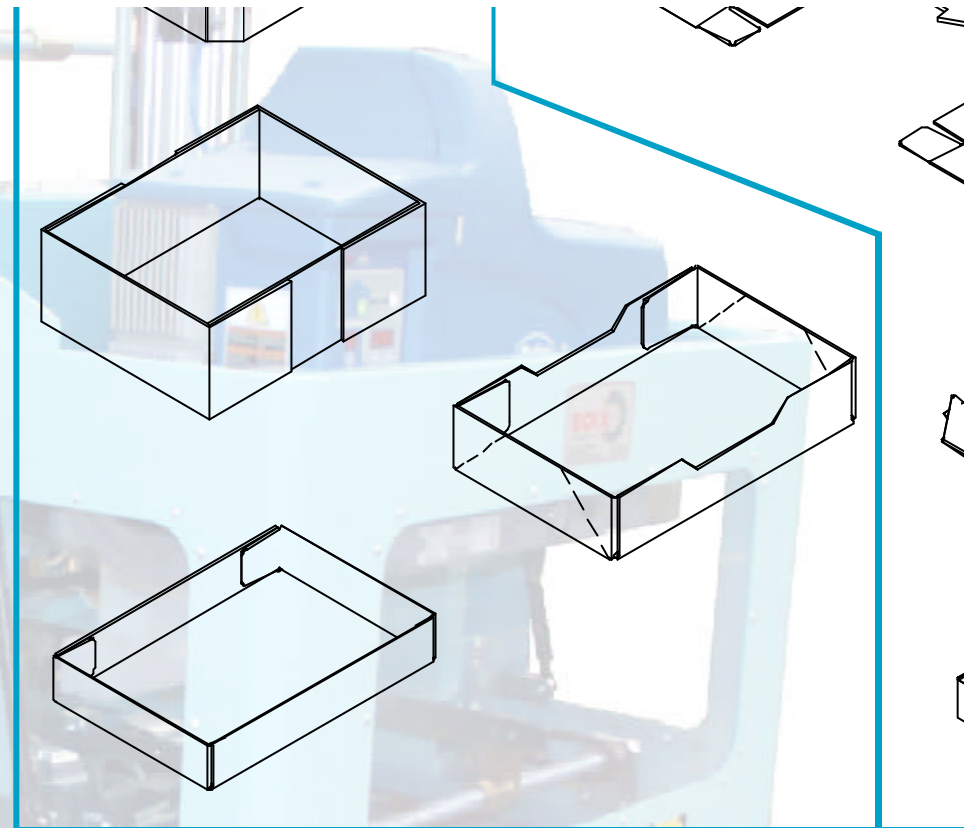
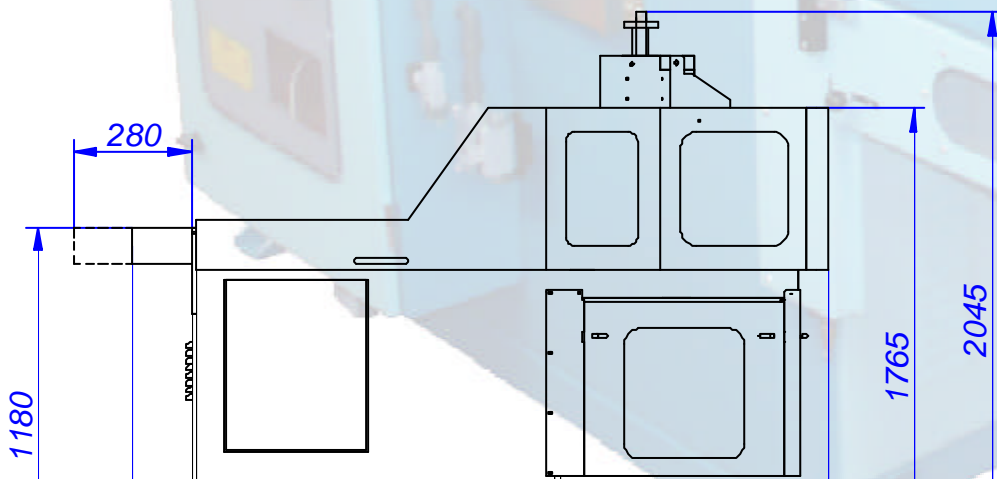

MAXIMUM AND MINIMUM SIZES (mm)

Para medidas diferentes a las especificadas,  
consultar a fábrica.

