

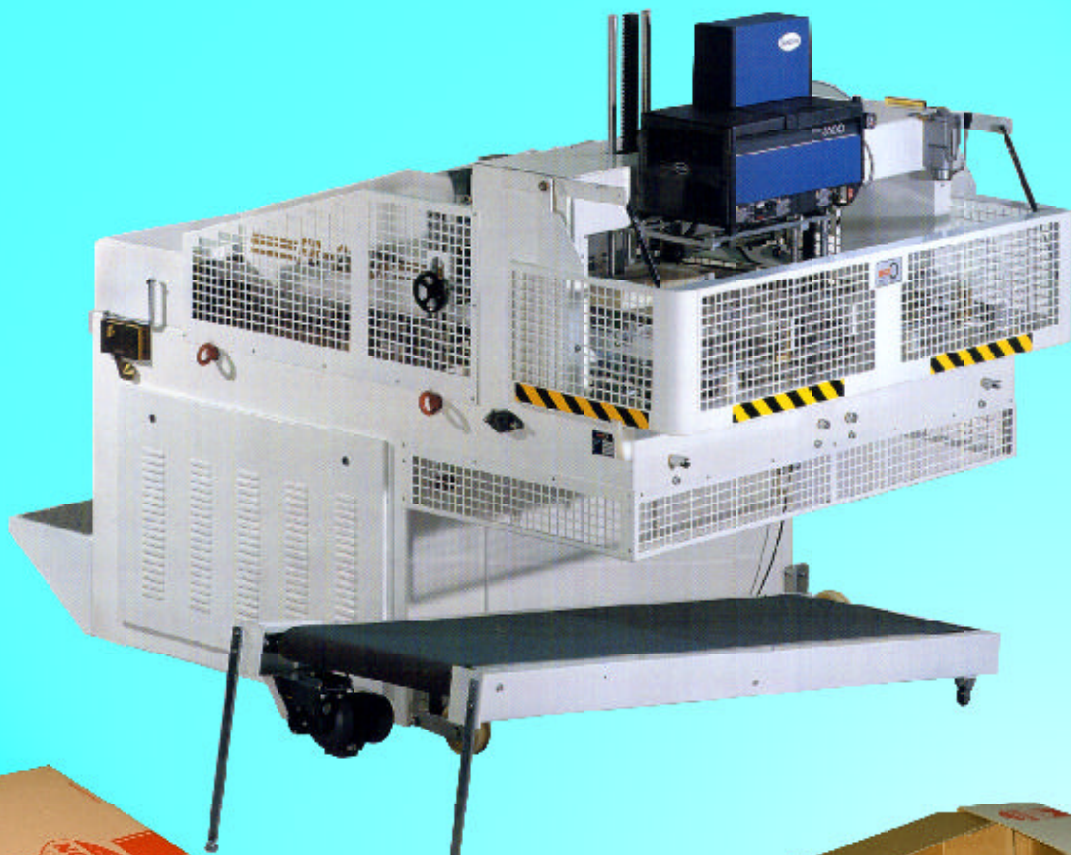

**MACHINE FOR FORMING AND GLUING  
CARDBOARD TRAYS OR BOXES**

# FB-20/DP



# FB-20 / DP

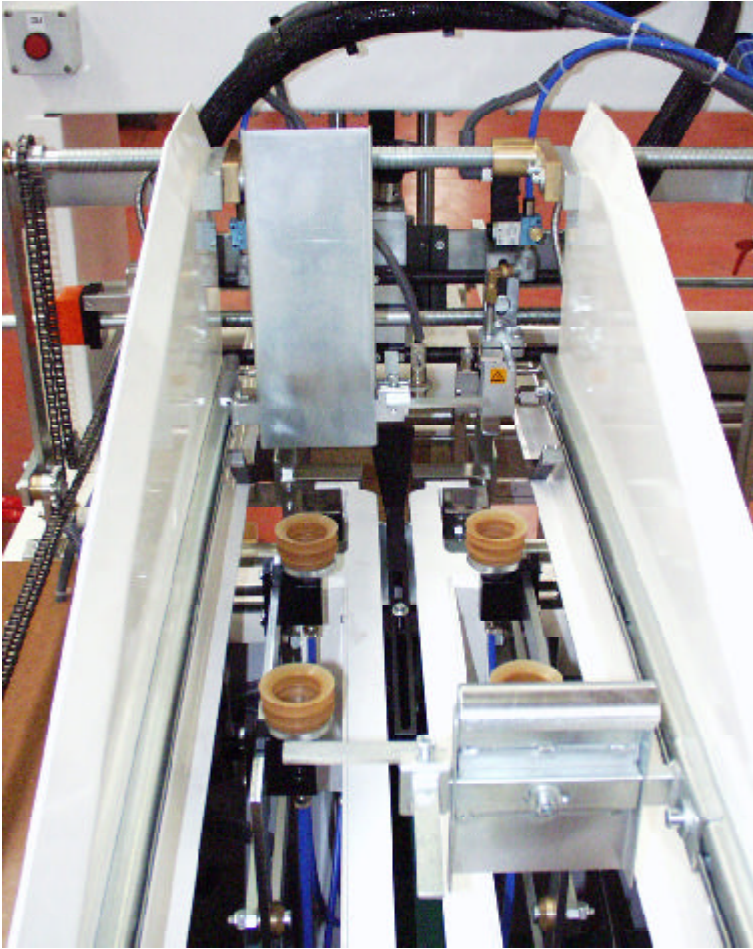

BLANKS FEEDER



GLUE PROGRAMMER  
80 boxes in memory

MOULD AREA

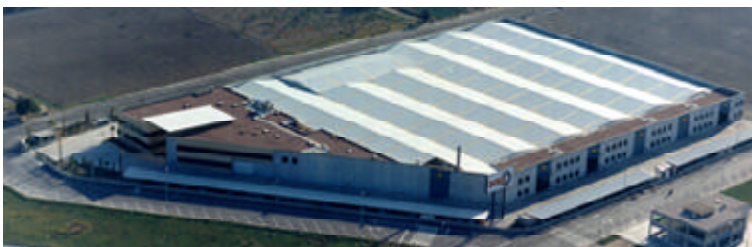
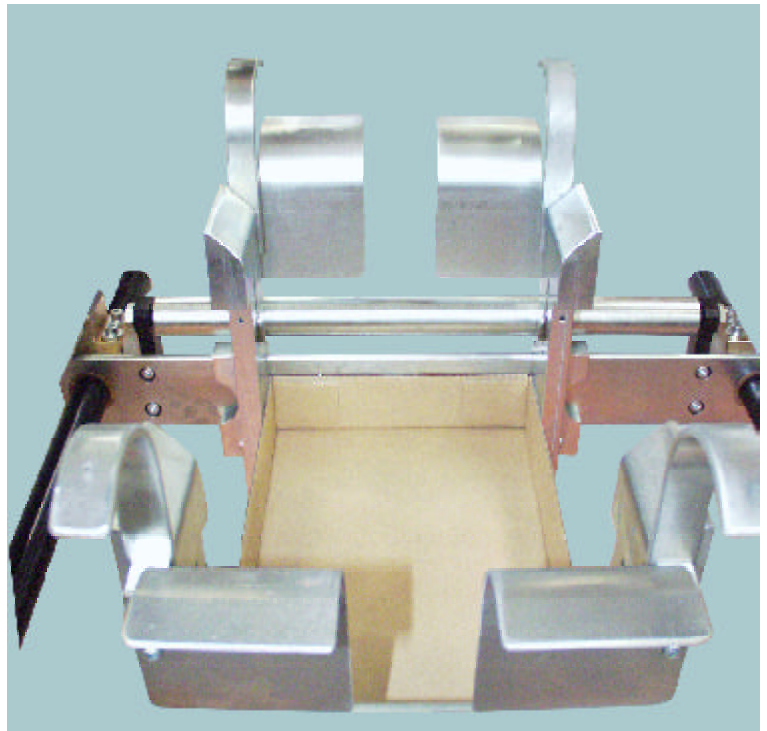

## Handelsonderneming Versleijen BV

Kerkvaart 1  
3641 EN Mijdrecht  
Holland  
Tel. +31 297-288506  
Fax. +31 297-288497  
E-mail: [info@versleijen.nl](mailto:info@versleijen.nl)  
Web: [www.versleijen.nl](http://www.versleijen.nl)

# FB-20/DP

**AUTOMATIC AND ADJUSTABLE TWIN HEADED MACHINE FOR GLUING AND FORMING** BOXES AND TRAYS IN CORRUGATED CARTON TYPE C-1, BASE AND LID SIMULTANEOUSLY OR INDIVIDUALLY.

TECHNICAL SPECIFICATIONS		FB-20/DP
OPERATION	Mechanic, pneumatic and electric	
GLUE SYSTEM	By injection, hot melt. Nordson (cap. 9 kg.)	
PRODUCTION	1.800 pieces / hour, each head	
TOTAL POWER	7 Kw. machine	0,6 Kw. Conveyor belt
ELECTRICAL SUPPLY <small>STANDARD</small>	380 v. (3P + N + E) - 50 Hz	
NET WEIGHT - kg.	1.600	
BLANK FEEDING SYSTEM	By vacuum	
SIZE CHANGE	15 – 30 min.	
AIR CONSUMPTION - l/min.	80 (iust for the glue injection)	
WORKING AIR PRESSURE	6 bar	
CONVEYOR BELT	OPTIONAL 2.600 X 600	

## ADDITIONAL INFORMATION :

- Machine totally mechanical, driven by one motor thus ensuring perfect synchronization of the two forming heads.
- Equipped with a timer for activating the hot melt equipment.
- Check-control and maintenance reminders by way of the programmer screen.
- Possibility to work «in line», the machine producing the boxes that the line demands with each forming head controlled independently.
- Central oil pump to facilitate ease of maintenance.

## MACHINE DIMENSIONS (mm) :

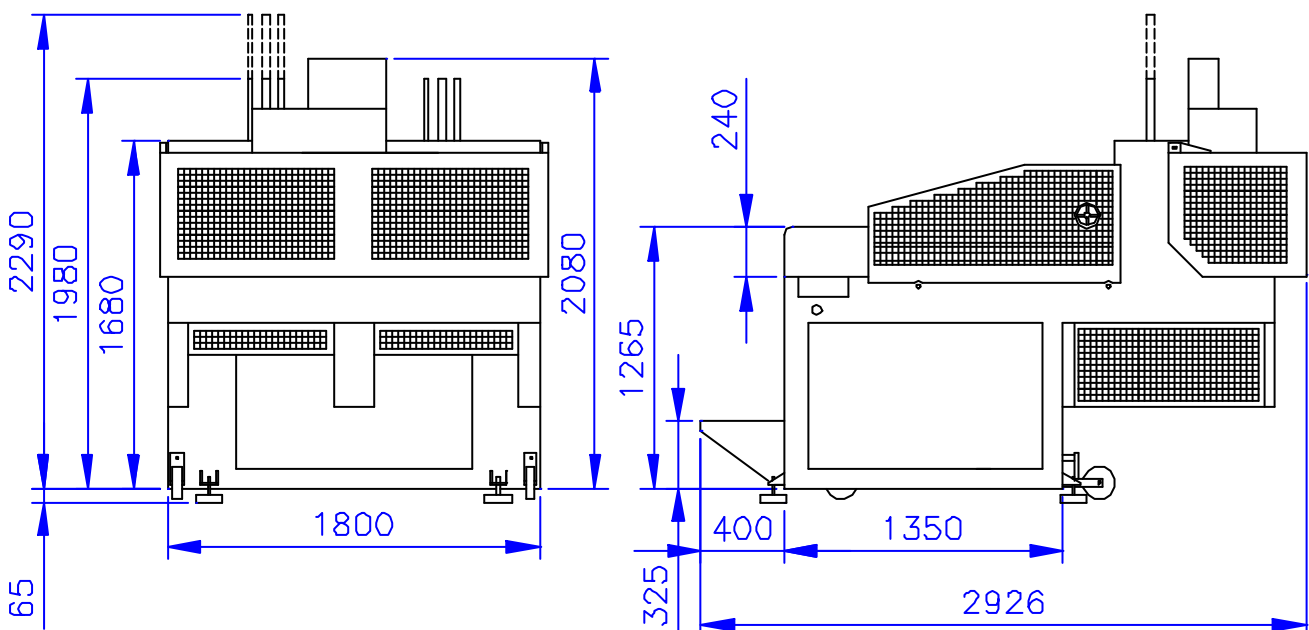

TECHNICAL SPECIFICATIONS (1-2)



PRODUCTION SAMPLES

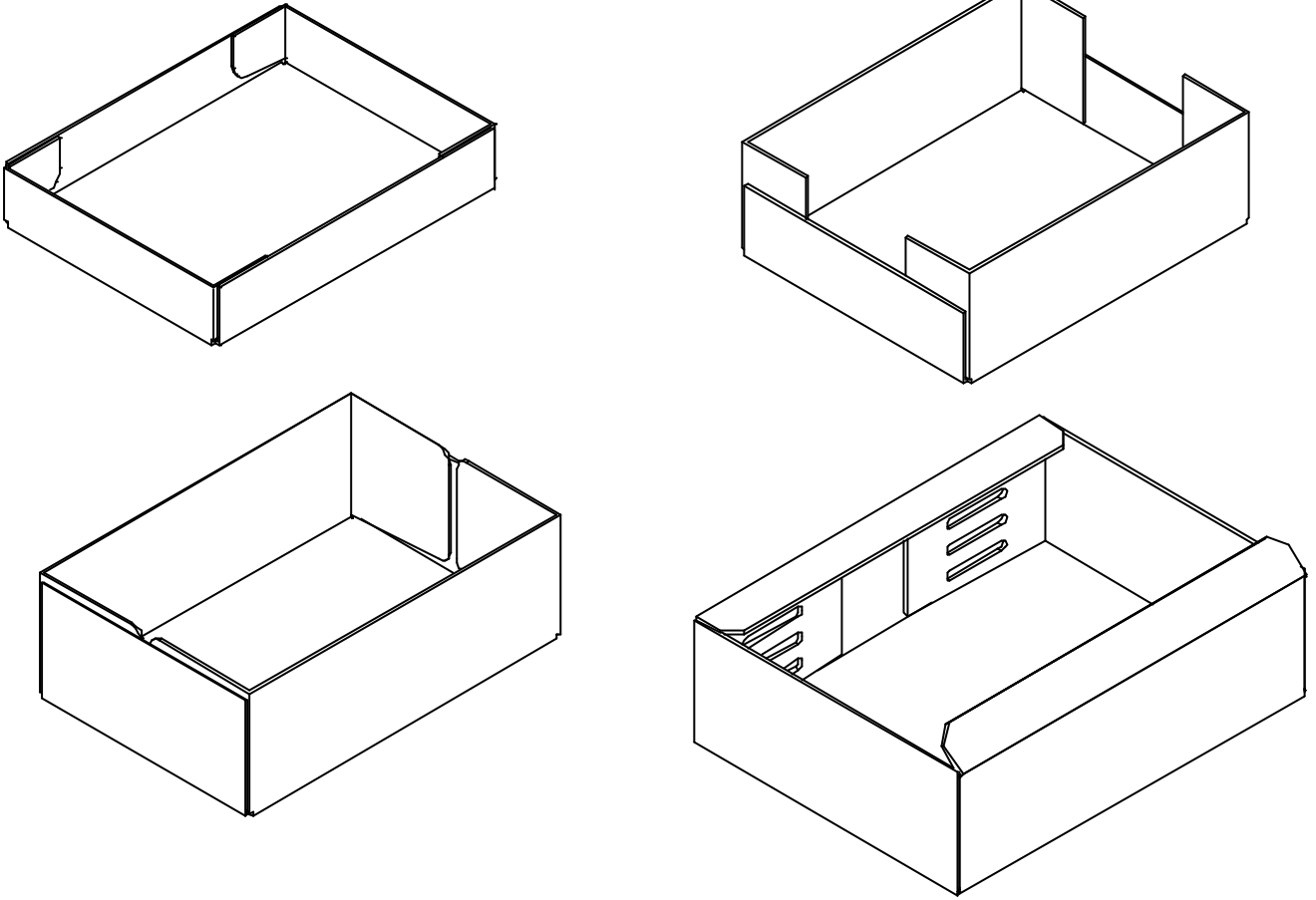

MAXIMUM AND MINIMUM SIZES (mm)

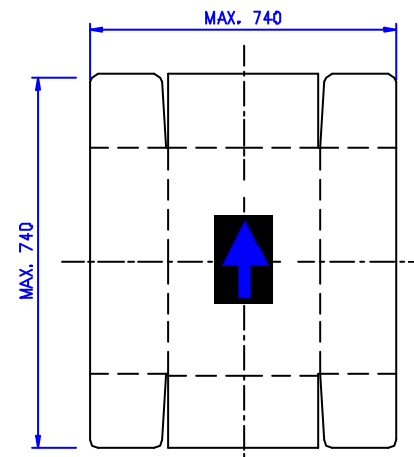

MEASUREMENTS NOT RELATED.

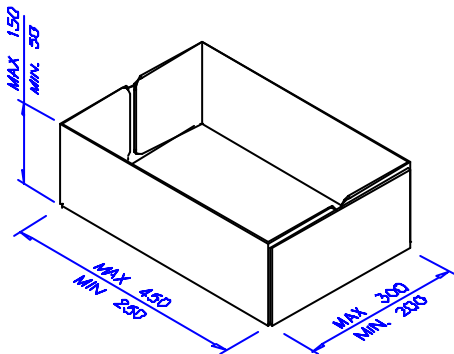

TO CALCULATE THE HEIGHT ; EXAMPLE :- BLANK 740 - BASE 450 =  $290/2 = H 145$  mm.

FORMING SEQUENCE

