



**MACHINE FOR FORMING AND GLUING  
CARDBOARD BOXES OR TRAYS**

**FB-20/D**



# FB-20/D

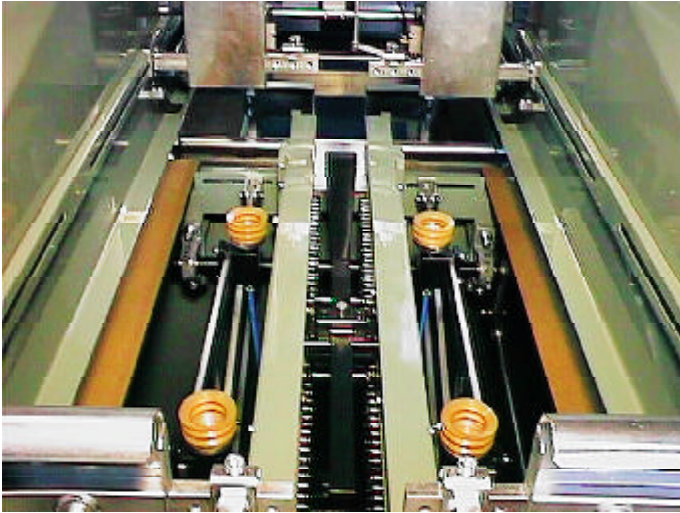

BLANKS FEEDER



GLUE PROGRAMMER  
80 boxes in memory

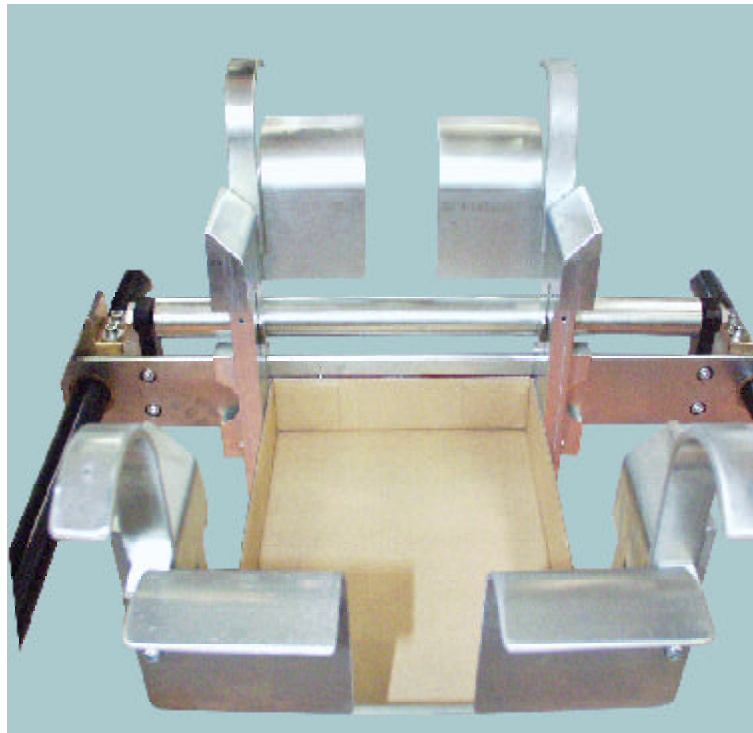

MOULD AREA

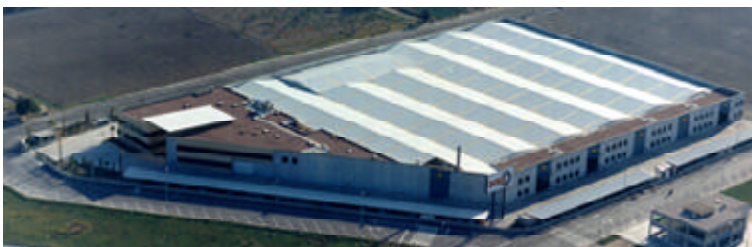

## Handelsonderneming Versleijen BV

Kerkvaart 1  
3641 EN Mijdrecht  
Holland

Tel. +31 297-288506

Fax. +31 297-288497

E-mail: [info@versleijen.nl](mailto:info@versleijen.nl)

Web: [www.versleijen.nl](http://www.versleijen.nl)

# FB-20/D

**AUTOMATIC AND ADJUSTABLE DOUBLE HEAD MACHINE FOR GLUING AND FORMING** BOXES AND TRAYS  
TYPE C-1 IN CORRUGATED CARTON, BASE AND LID SIMULTANEOUSLY OR INDIVIDUALLY.

TECHNICAL SPECIFICATIONS	FB-20/D	
OPERATION	Mechanic, pneumatic and electric	
GLUE SYSTEM	By injection, hot melt. Nordson (cap. 9 kg.)	
PRODUCTION	1.800 pieces / hour, each head	
TOTAL POWER	7 Kw. machine	0,6 Kw. Conveyor belt
ELECTRICAL SUPPLY <small>STANDARD</small>	380 v. (3P + N + E) - 50 Hz	
NET WEIGHT - kg.	1.880	
BLANK FEEDING SYSTEM	By vacuum	
SIZE CHANGE	15 – 30 min.	
AIR CONSUMPTION - l/min.	80 (iust for the glue injection)	
WORKING AIR PRESSURE	6 bar	
CONVEYOR BELT	OPTIONAL 2.600 X 600	

## ADDITIONAL INFORMATION :

- Totally mechanical machine, driven by one motor thus ensuring perfect synchronization of the two forming heads.
- Equipped with a timer for activating the glue equipment.
- Check-control and maintenance reminders by way of the programmer screen.
- Possibility to work «in-line», the machine producing the boxes that the line demands with each forming head controlled independently.
- Central oil pump for ease of maintenance.

## MACHINE DIMENSIONS (MM) :

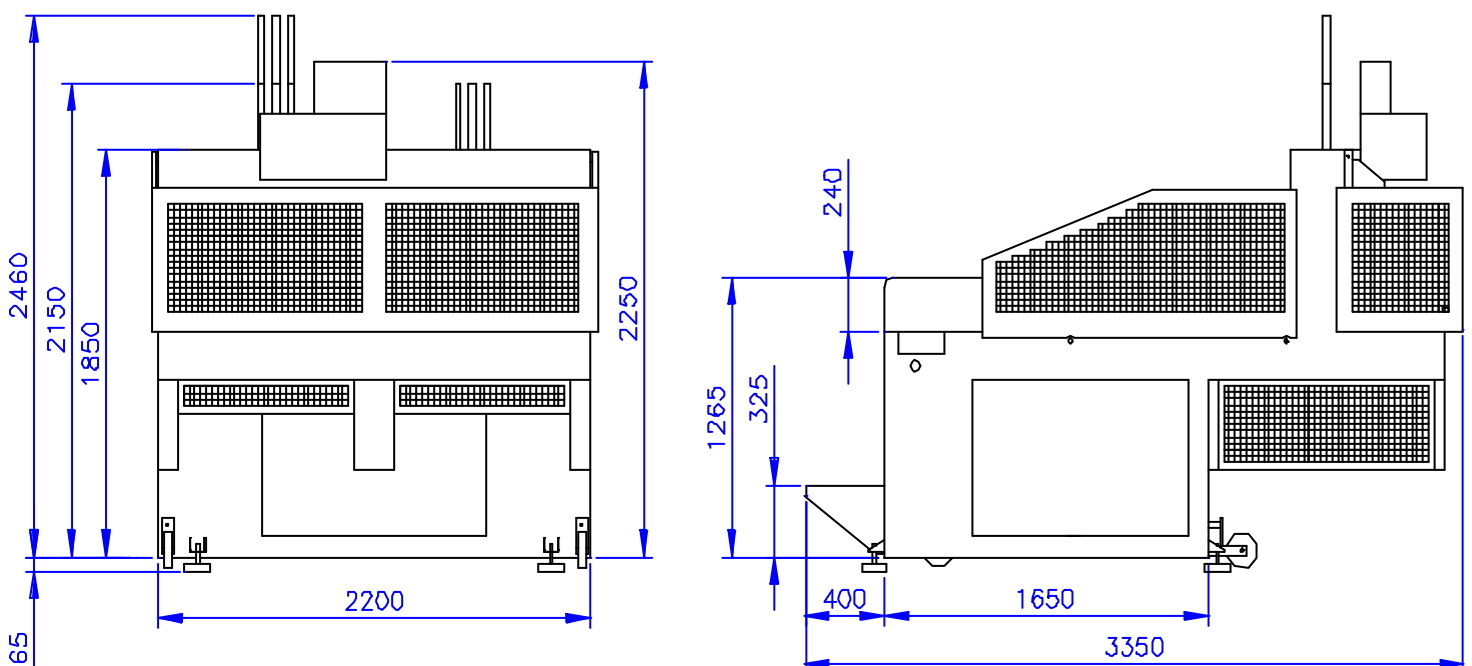

TECHNICAL SPECIFICATIONS (1-2)



PRODUCTION SAMPLES

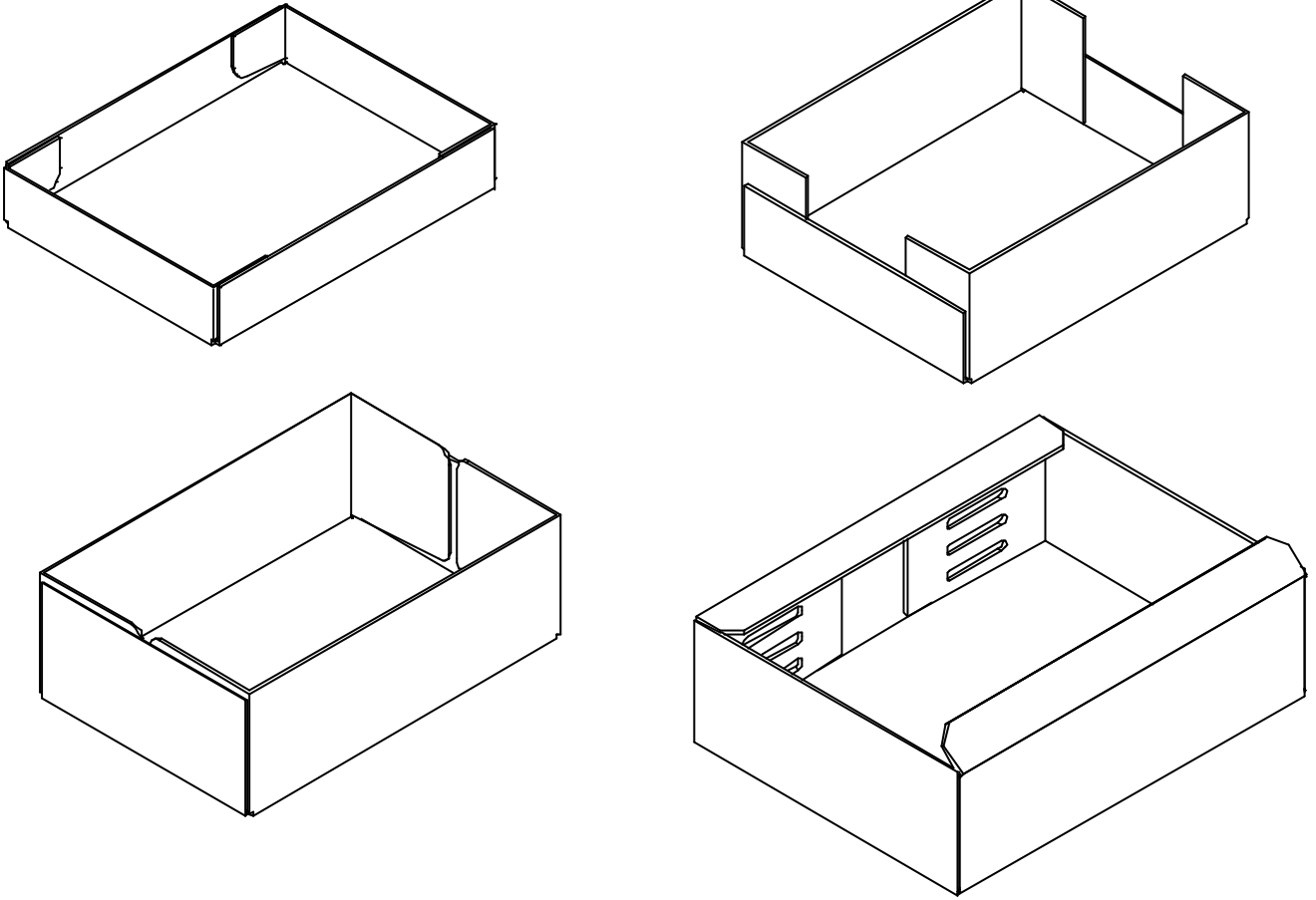

MAXIMUM AND MINIMUM SIZES

(mm)

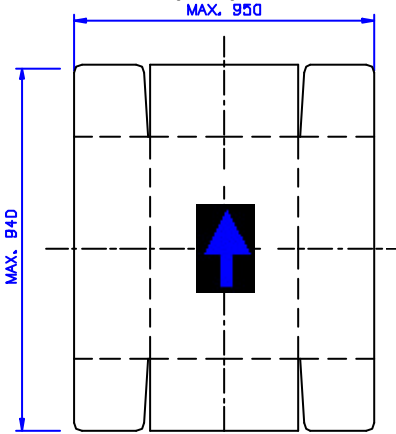

MEASUREMENTS NOT RELATED.

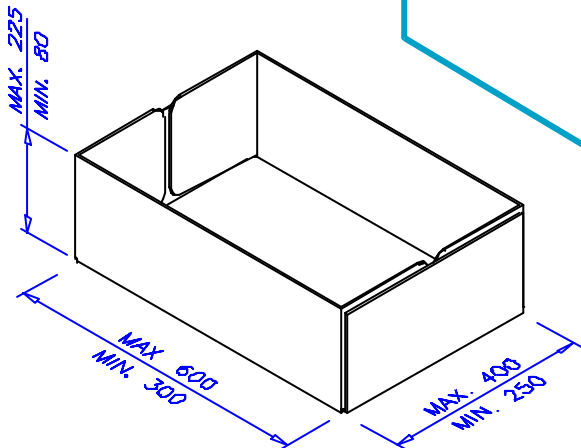

FORMING SEQUENCE

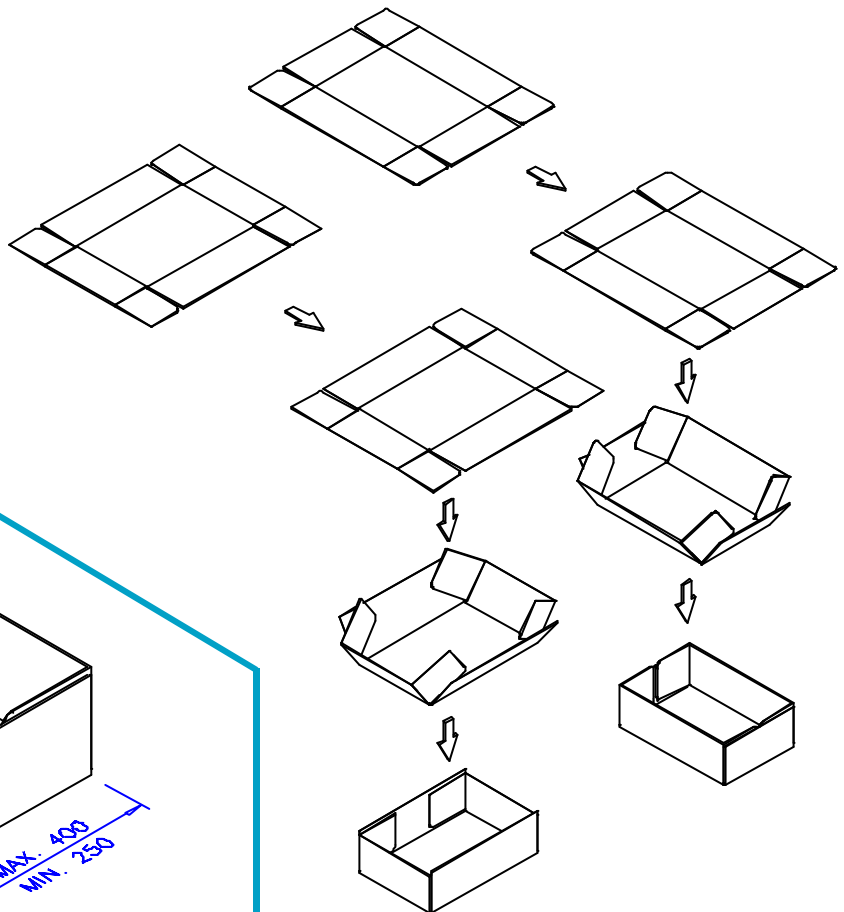

TO CALCULATE THE HEIGHT OF THE BOX : EXAMPLE ; BLANK 940 - BASE  
 $600 = 340/2 = H$  170 mm.